

# Royal Oak Drive @ Lochside Drive

Tuesday, March 03, 2020



The data presented here is for information purposes only and should not be considered authoritative for construction, geotechnical, engineering, navigational, legal, or other site-specific uses. The information shared is owned by the Transportation Division of the Engineering Department at the District of Saanich. Accuracy is not guaranteed.

**Major Route:** Royal Oak Drive  
**Minor Route:** Lochside Drive  
**Municipality:** Saanich  
**Filename:** Royal Oak Dr @ Lochside Dr-Mar 3, 2020.xlsx  
**Location #:** TIN000962  
**Count ID:** 202022  
**Date:** March 3, 2020  
**Day-of-week:** Tuesday

**East/West Route:** Royal Oak Drive  
**Intersection Type:** 4-leg  
**Signalized?:** Yes  
**Weather:** Clear and dry

**Vehicle Classifications:** Vehicles and Peds  
 Bikes

**This data is for Vehicles and Peds**

Shift	Start	End	Duration
AM	7:30	9:30	2.00
MD			
PM	15:30	18:30	3.00
<b>Total</b>	<b>7:30</b>	<b>18:30</b>	<b>5.00</b>

**Notes:** 24-hour clock used for reporting (15-minute increments)  
 North Approach - southbound vehicles approaching intersection from the north  
 15x4 - 15 min volume (from maximum 15 minute period of movement/approach in peak hour period [\*]) x 4  
 Pedestrians - N indicates pedestrians crossing north approach (east/west)

**Comments:**

Time Period Begins	Lochside Dr NORTH Approach				Lochside Dr SOUTH Approach				Royal Oak Dr WEST Approach				Royal Oak Dr EAST Approach				Total Volume		Ped	Crosswalks			
	Left	Thru	Right	Total	Left	Thru	Right	Total	Left	Thru	Right	Total	Left	Thru	Right	Total	15-min	Hour		N	S	W	E
7:30	23	0	6	29	0	0	1	1	3	104	3	110	0	131	3	134	274		0	0	0	0	
7:45	40	0	8	48	1	0	1	2	2	127	3	132	0	121	9	130	312		0	0	0	2	
8:00	28	1	14	43	2	0	1	3	8	165	12	185	2	169	10	181	412	*	0	5	0	6	
8:15	21	3	11	35	3	0	0	3	14	128	10	152	2	160	12	174	364	1362	*	8	21	0	43
8:30	25	1	17	43	13	0	2	15	10	173	6	189	0	190	18	208	455	1543	+	24	72	0	126
8:45	36	1	16	53	2	2	1	5	6	135	0	141	1	180	11	192	391	1622	*	4	13	0	30
9:00	22	0	18	40	1	0	0	1	11	125	0	136	0	133	11	144	321	1531		0	3	0	5
9:15	22	0	18	40	0	0	2	2	8	112	0	120	1	126	7	134	296	1463		0	2	0	4
n/a																							
n/a																							
n/a																							
n/a																							
n/a																							
n/a																							
n/a																							
n/a																							
n/a																							
n/a																							
n/a																							
n/a																							
n/a																							
Total	217	6	108	331	22	2	8	32	62	1069	34	1165	6	1210	81	1297	2825		36	116	0	216	

n/a																						
n/a																						
n/a																						
n/a																						
n/a																						
n/a																						
n/a																						
n/a																						
n/a																						
n/a																						
n/a																						
n/a																						
n/a																						
n/a																						
n/a																						
n/a																						
Total																						

15:30	21	0	14	35	0	0	4	4	7	155	0	162	3	145	15	163	364		*	0	10	0	9
15:45	18	0	12	30	3	0	1	4	10	128	0	138	1	180	21	202	374		+	0	8	0	8
16:00	10	0	8	18	2	1	1	4	5	155	0	160	3	169	12	184	366		*	0	0	0	7
16:15	10	0	9	19	3	0	0	3	12	151	1	164	0	148	18	166	352	1456	*	0	2	0	3
16:30	8	0	8	16	2	0	1	3	10	185	3	198	1	127	17	145	362	1454		0	0	0	3
16:45	13	0	3	16	1	0	3	4	5	167	4	176	0	146	16	162	358	1438		1	3	0	7
17:00	13	0	3	16	3	0	1	4	10	170	0	180	1	162	18	181	381	1453		2	0	0	0
17:15	14	1	3	18	3	0	0	3	12	176	1	189	0	117	17	134	344	1445		3	2	0	4
17:30	12	0	2	14	2	0	1	3	5	133	1	139	2	134	8	144	300	1383		4	0	0	1
17:45	15	0	2	17	5	0	1	6	7	155	2	164	0	103	13	116	303	1328		1	0	0	0
18:00	9	0	5	14	4	0	3	7	5	104	0	109	0	107	12	119	249	1196		1	0	0	1
18:15	16	0	3	19	1	0	1	2	10	112	1	123	1	105	16	122	266	1118		2	3	0	4
n/a																							
n/a																							
n/a																							
n/a																							
n/a																							
n/a																							
n/a																							
n/a																							
n/a																							
n/a																							
Total	159	1	72	232	29	1	17	47	98	1791	13	1902	12	1643	183	1838	4019			14	28	0	47

Time Period Begins	Lochside Dr NORTH Approach				Lochside Dr SOUTH Approach				Royal Oak Dr WEST Approach				Royal Oak Dr EAST Approach				Total Volume		Ped DL	Crosswalks				Conflict	
	Left	Thru	Right	Total	Left	Thru	Right	Total	Left	Thru	Right	Total	Left	Thru	Right	Total	15-min	Hour		N	S	W	E	15 min	Hr
	7:30	23	0	6	29	0	0	1	1	3	104	3	110	0	131	3	134	274			0	0	0	0	161
7:45	40	0	8	48	1	0	1	2	2	127	3	132	0	121	9	130	312		0	0	0	2	173		
8:00	28	1	14	43	2	0	1	3	8	165	12	185	2	169	10	181	412	*	0	5	0	6	216		
8:15	21	3	11	35	3	0	0	3	14	128	10	152	2	160	12	174	364	1362*	8	21	0	43	207	757	
8:30	25	1	17	43	13	0	2	15	10	173	6	189	0	190	18	208	455	1543+	24	72	0	126	249	845	
8:45	36	1	16	53	2	2	1	5	6	135	0	141	1	180	11	192	391	1622*	4	13	0	30	236	908	
9:00	22	0	18	40	1	0	0	1	11	125	0	136	0	133	11	144	321	1531	0	3	0	5	177	869	
9:15	22	0	18	40	0	0	2	2	8	112	0	120	1	126	7	134	296	1463	0	2	0	4	165	827	
n/a																									
n/a																									
n/a																									
n/a																									
n/a																									
n/a																									
n/a																									
n/a																									
n/a																									
n/a																									
n/a																									
n/a																									
n/a																									
n/a																									
n/a																									

Total	217	6	108	331	22	2	8	32	62	1069	34	1165	6	1210	81	1297	2825								36	116	0	216	1580				
Avg Hr	109	3	54	166	11	1	4	16	31	535	17	583	3	605	41	649	1413													18	58	0	108

Peak hour of the intersection

Pk Hr	110	6	58	174	20	2	4	26	38	601	28	667	5	699	51	755	1622*															36	111	0	205	904				
15x4	144	12	68	212	52	8	8	60	56	692	48	756	8	760	72	832	1820*																		96	288	0	504	1048	
PHF	0.76	0.50	0.85	0.82	0.38	0.25	0.50	0.43	0.68	0.87	0.58	0.88	0.63	0.92	0.71	0.91	0.89																			0.38	0.39	n/a	0.41	0.86

Peak hour of conflicting volumes for the intersection

Pk Hr	110	6	58	174	20	2	4	26	38	601	28	667	5	699	51	755	1622*																			36	111	0	205	904			
15x4	144	12	68	212	52	8	8	60	56	692	48	756	8	760	72	832	1820*																						96	288	0	504	1048
PHF	0.76	0.50	0.85	0.82	0.38	0.25	0.50	0.43	0.68	0.87	0.58	0.88	0.63	0.92	0.71	0.91	0.89																						0.38	0.39	n/a	0.41	0.86

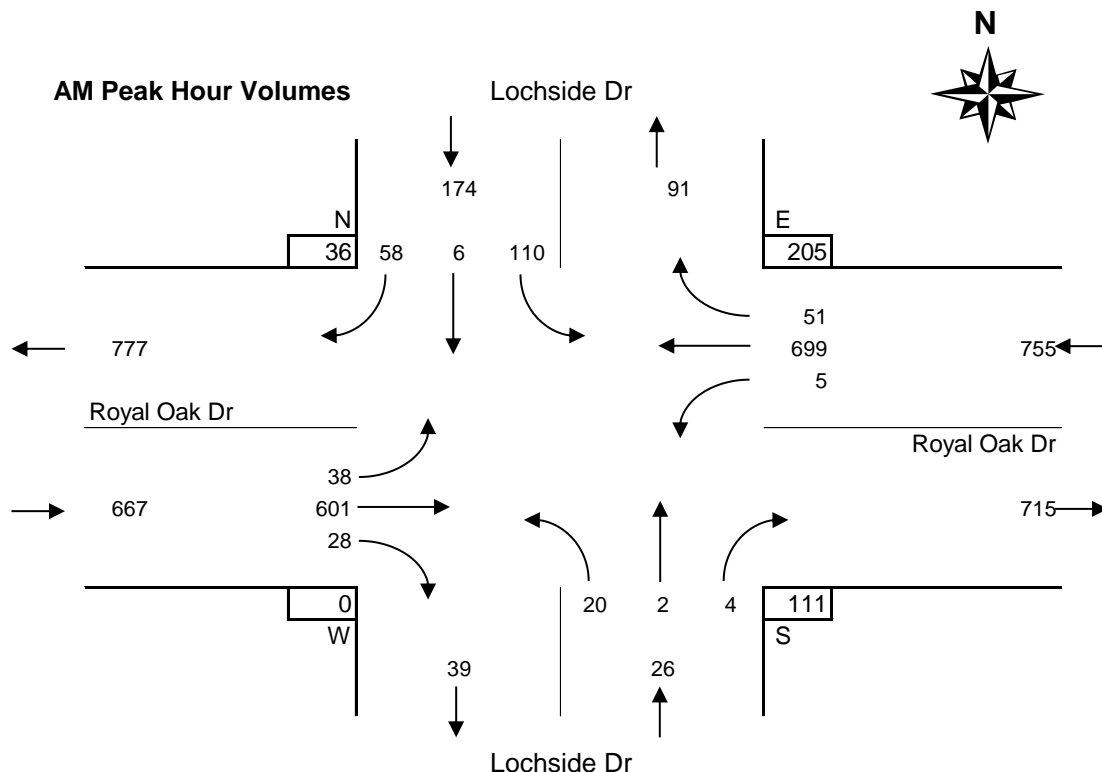

Time Period Begins	Lochside Dr				Lochside Dr				Royal Oak Dr				Royal Oak Dr				Total Volume		Pedestrians	Crosswalks				Conflict			
	NORTH Approach				SOUTH Approach				WEST Approach				EAST Approach				15-min	Hour		N	S	W	E	15 min	Hr		
n/a																											
n/a																											
n/a																											
n/a																											
n/a																											
n/a																											
n/a																											
n/a																											
n/a																											
n/a																											
n/a																											
n/a																											
n/a																											
n/a																											
n/a																											
n/a																											
n/a																											
n/a																											
n/a																											
n/a																											
n/a																											
n/a																											
n/a																											

Total																												
Avg Hr																												

**Peak hour of the intersection**

Pk Hr																												
15x4																												
PHF																												

**Peak hour of conflicting volumes for the intersection**

Pk Hr																												
15x4																												
PHF																												

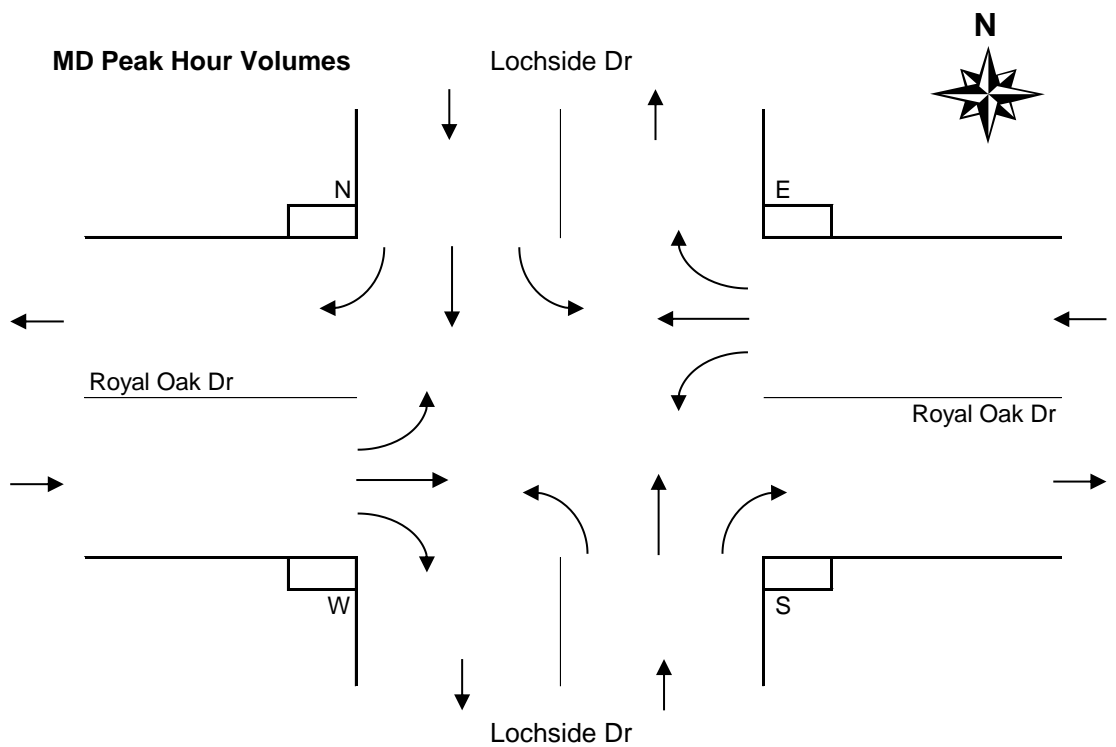

Time Period Begins	Lochside Dr NORTH Approach				Lochside Dr SOUTH Approach				Royal Oak Dr WEST Approach				Royal Oak Dr EAST Approach				Total Volume		Veh Ped	Crosswalks				Conflict	
	Left	Thru	Right	Total	Left	Thru	Right	Total	Left	Thru	Right	Total	Left	Thru	Right	Total	15-min	Hour		N	S	W	E	15 min	Hr
	15:30	21	0	14	35	0	0	4	4	7	155	0	162	3	145	15	163	364		*	0	10	0	9	192
15:45	18	0	12	30	3	0	1	4	10	128	0	138	1	180	21	202	374	+	0	8	0	8	230		
16:00	10	0	8	18	2	1	1	4	5	155	0	160	3	169	12	184	366	*	0	0	0	7	198		
16:15	10	0	9	19	3	0	0	3	12	151	1	164	0	148	18	166	352	1456*	0	2	0	3	190	810	
16:30	8	0	8	16	2	0	1	3	10	185	3	198	1	127	17	145	362	1454	0	0	0	3	199	817	
16:45	13	0	3	16	1	0	3	4	5	167	4	176	0	146	16	162	358	1438	1	3	0	7	187	774	
17:00	13	0	3	16	3	0	1	4	10	170	0	180	1	162	18	181	381	1453	2	0	0	0	204	780	
17:15	14	1	3	18	3	0	0	3	12	176	1	189	0	117	17	134	344	1445	3	2	0	4	191	781	
17:30	12	0	2	14	2	0	1	3	5	133	1	139	2	134	8	144	300	1383	4	0	0	1	160	742	
17:45	15	0	2	17	5	0	1	6	7	155	2	164	0	103	13	116	303	1328	1	0	0	0	173	728	
18:00	9	0	5	14	4	0	3	7	5	104	0	109	0	107	12	119	249	1196	1	0	0	1	136	660	
18:15	16	0	3	19	1	0	1	2	10	112	1	123	1	105	16	122	266	1118	2	3	0	4	148	617	
n/a																									
n/a																									
n/a																									
n/a																									
n/a																									
n/a																									
n/a																									
n/a																									
n/a																									
n/a																									
n/a																									
n/a																									

Total	159	1	72	232	29	1	17	47	98	1791	13	1902	12	1643	183	1838	4019		14	28	0	47	2101
Avg Hr	53	0	24	77	10	0	6	16	33	597	4	634	4	548	61	613	1340		5	9	0	16	

**Peak hour of the intersection**

Pk Hr	59	0	43	102	8	1	6	15	34	589	1	624	7	642	66	715	1456	*	0	20	0	27	808
15x4	84	0	56	140	12	4	16	16	48	620	4	656	12	720	84	808	1496	+	0	40	0	36	956
PHF	0.70	n/a	0.77	0.73	0.67	0.25	0.38	0.94	0.71	0.95	0.25	0.95	0.58	0.89	0.79	0.88	0.97		n/a	0.50	n/a	0.75	0.85

**Peak hour of conflicting volumes for the intersection**

Pk Hr	46	0	37	83	10	1	3	14	37	619	4	660	5	624	68	697	1454	*	0	10	0	21	779
15x4	72	0	48	120	12	4	4	16	48	740	12	792	12	720	84	808	1496	+	0	32	0	32	932
PHF	0.64	n/a	0.77	0.69	0.83	0.25	0.75	0.88	0.77	0.84	0.33	0.83	0.42	0.87	0.81	0.86	0.97		n/a	0.31	n/a	0.66	0.84

\*\* Calculated peak hour occurs during the first or last hour of shift and therefore may be invalid. \*\* N

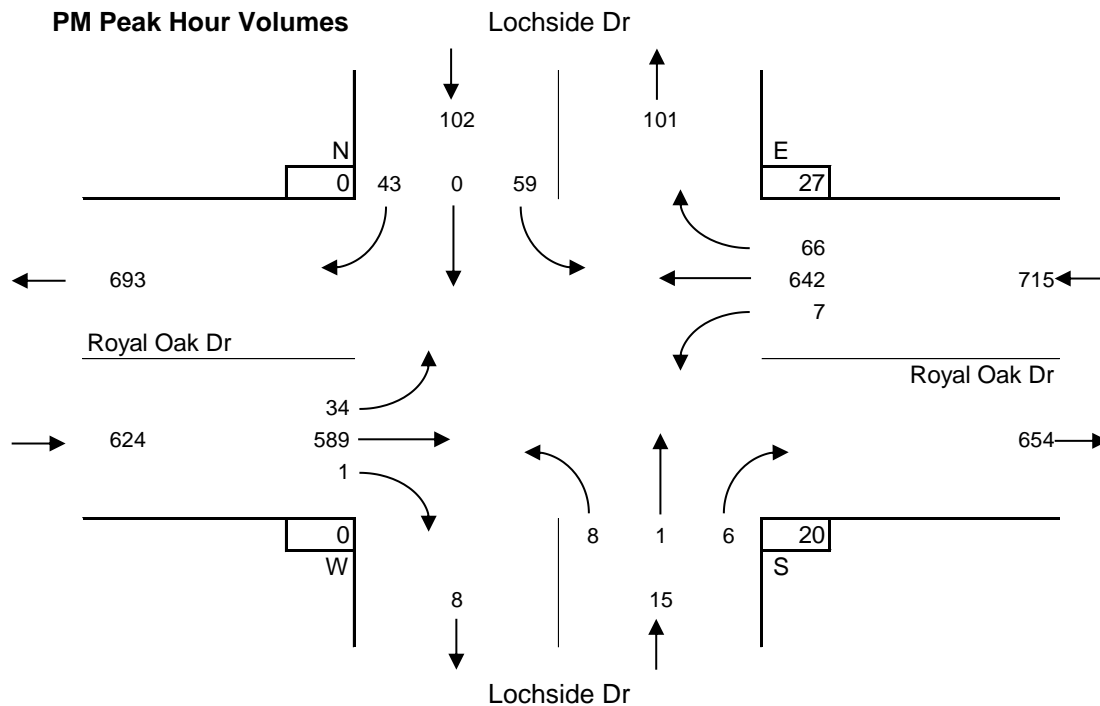

Entire Survey Period

5 Hours

	Lochside Dr				Lochside Dr				Royal Oak Dr				Royal Oak Dr				Total Volume	Crosswalks			
	NORTH Approach				SOUTH Approach				WEST Approach				EAST Approach					N	S	W	E
	Left	Thru	Right	Total	Left	Thru	Right	Total	Left	Thru	Right	Total	Left	Thru	Right	Total					
Total	376	7	180	563	51	3	25	79	160	2860	47	3067	18	2853	264	3135	6844	50	144	0	263
Avg Hr	75	1	36	113	10	1	5	16	32	572	9	613	4	571	53	627	1369	10	29	0	53

AM Peak Period

2 Hours

	Lochside Dr				Lochside Dr				Royal Oak Dr				Royal Oak Dr				Total Volume	Crosswalks			
	NORTH Approach				SOUTH Approach				WEST Approach				EAST Approach					N	S	W	E
	Left	Thru	Right	Total	Left	Thru	Right	Total	Left	Thru	Right	Total	Left	Thru	Right	Total					
Totals	217	6	108	331	22	2	8	32	62	1069	34	1165	6	1210	81	1297	2825	36	116	0	216
Avg Hr	109	3	54	166	11	1	4	16	31	535	17	583	3	605	41	649	1413	18	58	0	108

MD Peak Period

Hours

	Lochside Dr				Lochside Dr				Royal Oak Dr				Royal Oak Dr				Total Volume	Crosswalks			
	NORTH Approach				SOUTH Approach				WEST Approach				EAST Approach					N	S	W	E
	Left	Thru	Right	Total	Left	Thru	Right	Total	Left	Thru	Right	Total	Left	Thru	Right	Total					
Total																					
Avg Hr																					

PM Peak Period

3 Hours

	Lochside Dr				Lochside Dr				Royal Oak Dr				Royal Oak Dr				Total Volume	Crosswalks			
	NORTH Approach				SOUTH Approach				WEST Approach				EAST Approach					N	S	W	E
	Left	Thru	Right	Total	Left	Thru	Right	Total	Left	Thru	Right	Total	Left	Thru	Right	Total					
Total	159	1	72	232	29	1	17	47	98	1791	13	1902	12	1643	183	1838	4019	14	28	0	47
Avg Hr	53	0	24	77	10	0	6	16	33	597	4	634	4	548	61	613	1340	5	9	0	16

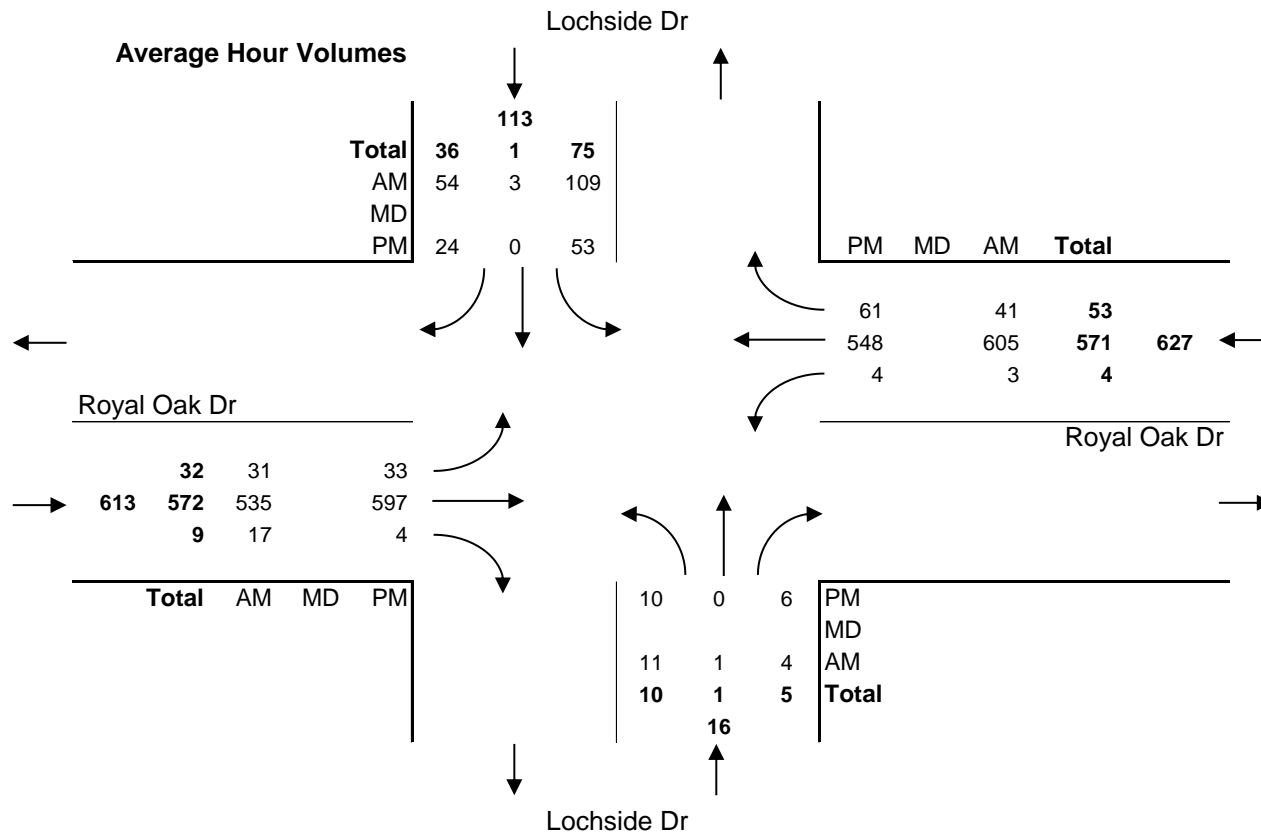

**Major Route:** Royal Oak Drive  
**Minor Route:** Lochside Drive  
**Municipality:** Saanich  
**Filename:** Royal Oak Dr @ Lochside Dr-Mar 3, 2020.xlsx  
**Location #:** TIN000962  
**Count ID:** 202022  
**Date:** March 3, 2020  
**Day-of-week:** Tuesday

**East/West Route:** Royal Oak Drive  
**Intersection Type:** 4-leg  
**Signalized?:** Yes  
**Weather:** Clear and dry

**Vehicle Classifications:** Vehicles and Peds  
 Bikes

**This data is for Bikes**

Shift	Start	End	Duration
AM	7:30	9:30	2.00
MD			
PM	15:30	18:30	3.00
<b>Total</b>	<b>7:30</b>	<b>18:30</b>	<b>5.00</b>

**Notes:** 24-hour clock used for reporting (15-minute increments)  
 North Approach - southbound vehicles approaching intersection from the north  
 15x4 - 15 min volume (from maximum 15 minute period of movement/approach in peak hour period [\*]) x 4  
 Pedestrians - N indicates pedestrians crossing north approach (east/west)

**Comments:**



**Survey Data**  
Bikes

**Royal Oak Drive @ Lochside Drive**  
Tuesday, March 3, 2020

Time Period Begins	Lochside Dr NORTH Approach				Lochside Dr SOUTH Approach				Royal Oak Dr WEST Approach				Royal Oak Dr EAST Approach				Total Volume		Speed	N	S	W	E
	Left	Thru	Right	Total	Left	Thru	Right	Total	Left	Thru	Right	Total	Left	Thru	Right	Total	15-min	Hour					
7:30	0	11	0	11	0	1	0	1	0	0	3	3	2	0	0	2	17		*	0	0	0	0
7:45	2	6	0	8	0	7	0	7	0	2	3	5	2	0	1	3	23		+	0	0	0	0
8:00	0	9	0	9	1	4	0	5	1	1	1	3	1	1	1	3	20		*	0	0	0	0
8:15	0	2	0	2	0	3	1	4	0	2	2	4	0	0	2	2	12	72	*	0	0	0	0
8:30	0	4	0	4	1	4	0	5	0	3	2	5	1	0	0	1	15	70		0	0	0	0
8:45	0	4	0	4	0	1	0	1	0	0	3	3	2	0	1	3	11	58		0	0	0	0
9:00	0	6	1	7	0	1	0	1	0	1	0	1	0	0	0	0	9	47		0	0	0	0
9:15	0	2	0	2	0	2	0	2	1	0	0	1	0	2	1	3	8	43		0	0	0	0
n/a																							
n/a																							
n/a																							
n/a																							
n/a																							
n/a																							
n/a																							
n/a																							
n/a																							
n/a																							
n/a																							
n/a																							
n/a																							
n/a																							
Total	2	44	1	47	2	23	1	26	2	9	14	25	8	3	6	17	115			0	0	0	0

n/a																							
n/a																							
n/a																							
n/a																							
n/a																							
n/a																							
n/a																							
n/a																							
n/a																							
n/a																							
n/a																							
n/a																							
n/a																							
n/a																							
n/a																							
n/a																							
n/a																							
Total																							

15:30	1	3	1	5	1	4	0	5	0	0	0	0	0	2	2	4	14			0	0	0	0
15:45	2	1	0	3	0	3	0	3	1	0	1	2	0	0	1	1	9			0	0	0	0
16:00	1	1	1	3	0	5	0	5	0	1	0	1	0	0	0	0	9			0	0	0	0
16:15	1	2	0	3	1	5	0	6	0	0	1	1	0	1	2	3	13	45		0	0	0	0
16:30	0	4	1	5	0	4	1	5	0	2	1	3	0	0	0	0	13	44	*	0	0	0	0
16:45	0	4	1	5	3	13	3	19	1	0	2	3	0	1	0	1	28	63	+	0	0	0	0
17:00	0	4	0	4	4	9	5	18	0	2	1	3	0	0	0	0	25	79	*	0	0	0	0
17:15	0	2	0	2	5	5	1	11	1	4	0	5	0	1	0	1	19	85	*	0	0	0	0
17:30	1	0	1	2	2	6	0	8	0	0	0	0	0	2	0	2	12	84		0	0	0	0
17:45	0	4	1	5	0	1	2	3	0	0	0	0	1	0	0	1	9	65		0	0	0	0
18:00	0	0	1	1	0	2	1	3	0	0	0	0	0	0	1	1	5	45		0	0	0	0
18:15	1	1	0	2	1	6	1	8	0	0	0	0	0	0	0	0	10	36		0	0	0	0
n/a																							
n/a																							
n/a																							
n/a																							
n/a																							
n/a																							
n/a																							
n/a																							
n/a																							
n/a																							
Total	7	26	7	40	17	63	14	94	3	9	6	18	1	7	6	14	166			0	0	0	0

Time Period Begins	Lochside Dr NORTH Approach				Lochside Dr SOUTH Approach				Royal Oak Dr WEST Approach				Royal Oak Dr EAST Approach				Total Volume		Sat. P.L.	Conflict				
	Left	Thru	Right	Total	Left	Thru	Right	Total	Left	Thru	Right	Total	Left	Thru	Right	Total	15-min	Hour		N	S	W	E	15 min
7:30	0	11	0	11	0	1	0	1	0	0	3	3	2	0	0	2	17	*	0	0	0	0	16	
7:45	2	6	0	8	0	7	0	7	0	2	3	5	2	0	1	3	23	+	0	0	0	0	16	
8:00	0	9	0	9	1	4	0	5	1	1	1	3	1	1	1	3	20	*	0	0	0	0	13	
8:15	0	2	0	2	0	3	1	4	0	2	2	4	0	0	2	2	12	72*	0	0	0	0	8	53
8:30	0	4	0	4	1	4	0	5	0	3	2	5	1	0	0	1	15	70	0	0	0	0	11	48
8:45	0	4	0	4	0	1	0	1	0	0	3	3	2	0	1	3	11	58	0	0	0	0	9	41
9:00	0	6	1	7	0	1	0	1	0	1	0	1	0	0	0	0	9	47	0	0	0	0	8	36
9:15	0	2	0	2	0	2	0	2	1	0	0	1	0	2	1	3	8	43	0	0	0	0	6	34
n/a																								
n/a																								
n/a																								
n/a																								
n/a																								
n/a																								
n/a																								
n/a																								
n/a																								
n/a																								
n/a																								
n/a																								
n/a																								
n/a																								
n/a																								

Total	2	44	1	47	2	23	1	26	2	9	14	25	8	3	6	17	115		0	0	0	0	78
Avg Hr	1	22	1	24	1	12	1	13	1	5	7	13	4	2	3	9	58		0	0	0	0	

Peak hour of the intersection

Pk Hr	2	28	0	30	1	15	1	17	1	5	9	15	5	1	4	10	72*		0	0	0	0	48
15x4	8	44	0	44	4	28	4	28	4	8	12	20	8	4	8	12	92*		0	0	0	0	76
PHF	0.25	0.64	n/a	0.68	0.25	0.54	0.25	0.61	0.25	0.63	0.75	0.75	0.63	0.25	0.50	0.83	0.78		n/a	n/a	n/a	n/a	0.63

Peak hour of conflicting volumes for the intersection

Pk Hr	2	28	0	30	1	15	1	17	1	5	9	15	5	1	4	10	72*		0	0	0	0	48
15x4	8	44	0	44	4	28	4	28	4	8	12	20	8	4	8	12	92*		0	0	0	0	76
PHF	0.25	0.64	n/a	0.68	0.25	0.54	0.25	0.61	0.25	0.63	0.75	0.75	0.63	0.25	0.50	0.83	0.78		n/a	n/a	n/a	n/a	0.63

\*\* Calculated peak hour occurs during the first or last hour of shift and therefore may be invalid. \*\*

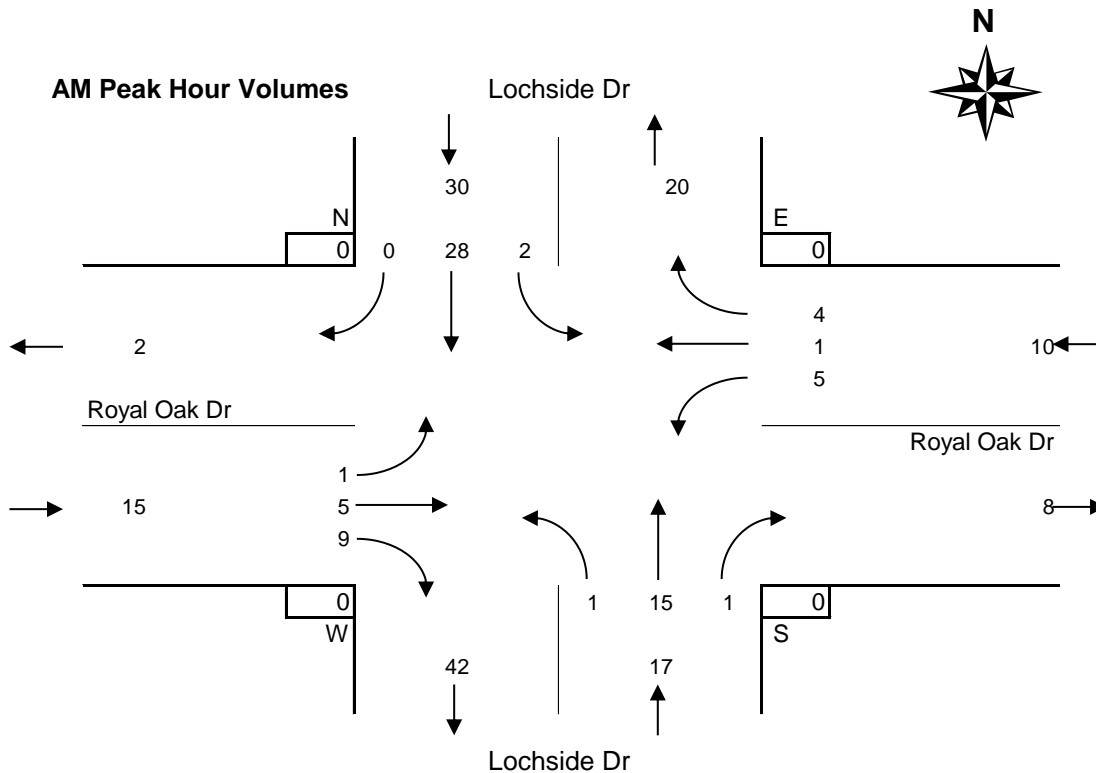

Time Period Begins	Lochside Dr				Lochside Dr				Royal Oak Dr				Royal Oak Dr				Total Volume		Pedestrian	Conflict								
	NORTH Approach				SOUTH Approach				WEST Approach				EAST Approach				15-min	Hour		N	S	W	E	15 min	Hr			
n/a																												
n/a																												
n/a																												
n/a																												
n/a																												
n/a																												
n/a																												
n/a																												
n/a																												
n/a																												
n/a																												
n/a																												
n/a																												
n/a																												
n/a																												
n/a																												
n/a																												
n/a																												
n/a																												
n/a																												
n/a																												
n/a																												
n/a																												
n/a																												
n/a																												
n/a																												
n/a																												
n/a																												
n/a																												
n/a																												

Total																													
Avg Hr																													

**Peak hour of the intersection**

Pk Hr																													
15x4																													
PHF																													

**Peak hour of conflicting volumes for the intersection**

Pk Hr																													
15x4																													
PHF																													

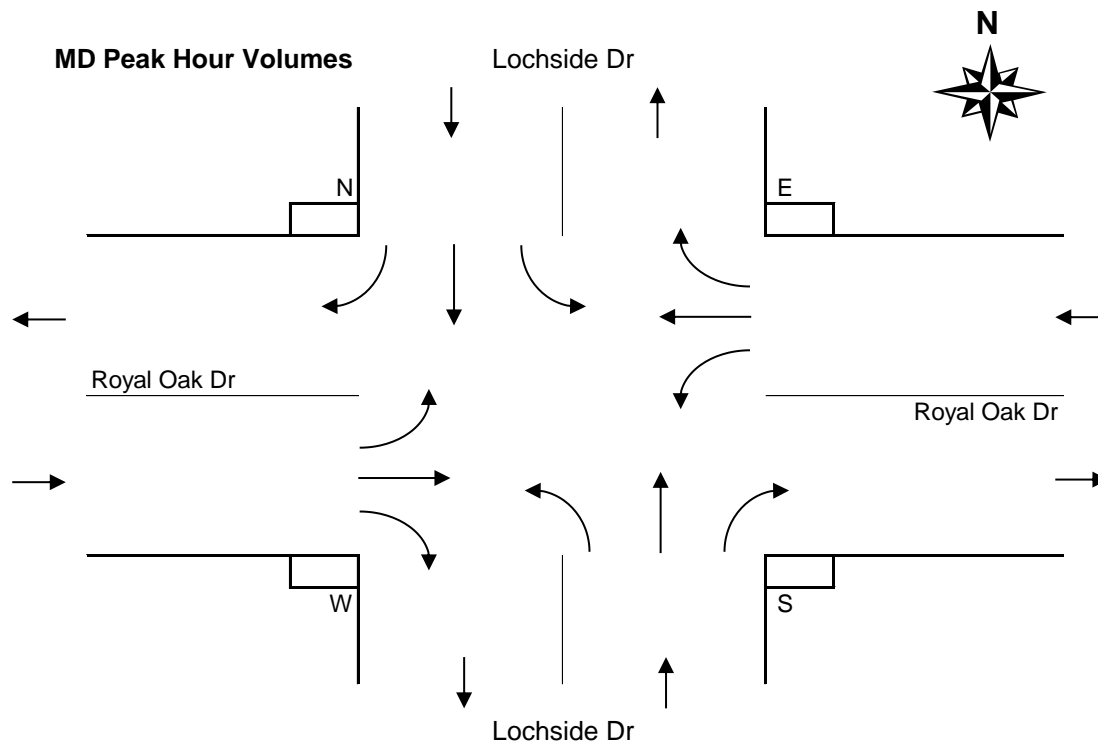

Time Period Begins	Lochside Dr NORTH Approach				Lochside Dr SOUTH Approach				Royal Oak Dr WEST Approach				Royal Oak Dr EAST Approach				Total Volume		Ped DL	Conflict				
	Left	Thru	Right	Total	Left	Thru	Right	Total	Left	Thru	Right	Total	Left	Thru	Right	Total	15-min	Hour		N	S	W	E	15 min
15:30	1	3	1	5	1	4	0	5	0	0	0	0	0	2	2	4	14		0	0	0	0	9	
15:45	2	1	0	3	0	3	0	3	1	0	1	2	0	0	1	1	9		0	0	0	0	7	
16:00	1	1	1	3	0	5	0	5	0	1	0	1	0	0	0	0	9		0	0	0	0	7	
16:15	1	2	0	3	1	5	0	6	0	0	1	1	0	1	2	3	13	45	0	0	0	0	9	32
16:30	0	4	1	5	0	4	1	5	0	2	1	3	0	0	0	0	13	44*	0	0	0	0	8	31
16:45	0	4	1	5	3	13	3	19	1	0	2	3	0	1	0	1	28	63+	0	0	0	0	18	42
17:00	0	4	0	4	4	9	5	18	0	2	1	3	0	0	0	0	25	79*	0	0	0	0	17	52
17:15	0	2	0	2	5	5	1	11	1	4	0	5	0	1	0	1	19	85*	0	0	0	0	11	54
17:30	1	0	1	2	2	6	0	8	0	0	0	0	0	2	0	2	12	84	0	0	0	0	9	55
17:45	0	4	1	5	0	1	2	3	0	0	0	0	1	0	0	1	9	65	0	0	0	0	6	43
18:00	0	0	1	1	0	2	1	3	0	0	0	0	0	0	1	1	5	45	0	0	0	0	4	30
18:15	1	1	0	2	1	6	1	8	0	0	0	0	0	0	0	0	10	36	0	0	0	0	8	27
n/a																								
n/a																								
n/a																								
n/a																								
n/a																								
n/a																								
n/a																								
n/a																								
n/a																								
n/a																								
n/a																								

Total	7	26	7	40	17	63	14	94	3	9	6	18	1	7	6	14	166							
Avg Hr	2	9	2	13	6	21	5	31	1	3	2	6	0	2	2	5	55							

0	0	0	0
0	0	0	0

100
-----

**Peak hour of the intersection**

Pk Hr	0	14	2	16	12	31	10	53	2	8	4	14	0	2	0	2	85*
15x4	0	16	4	20	20	52	20	76	4	16	8	20	0	4	0	4	112+
PHF	n/a	0.88	0.50	0.80	0.60	0.60	0.50	0.70	0.50	0.50	0.50	0.70	n/a	0.50	n/a	0.50	0.76

0	0	0	0
0	0	0	0
n/a	n/a	n/a	n/a

53
96
0.55

**Peak hour of conflicting volumes for the intersection**

Pk Hr	1	10	2	13	14	33	9	56	2	6	3	11	0	4	0	4	84*
15x4	4	16	4	20	20	52	20	76	4	16	8	20	0	8	0	8	112+
PHF	0.25	0.63	0.50	0.65	0.70	0.63	0.45	0.74	0.50	0.38	0.38	0.55	n/a	0.50	n/a	0.50	0.75

0	0	0	0
0	0	0	0
n/a	n/a	n/a	n/a

52
100
0.52

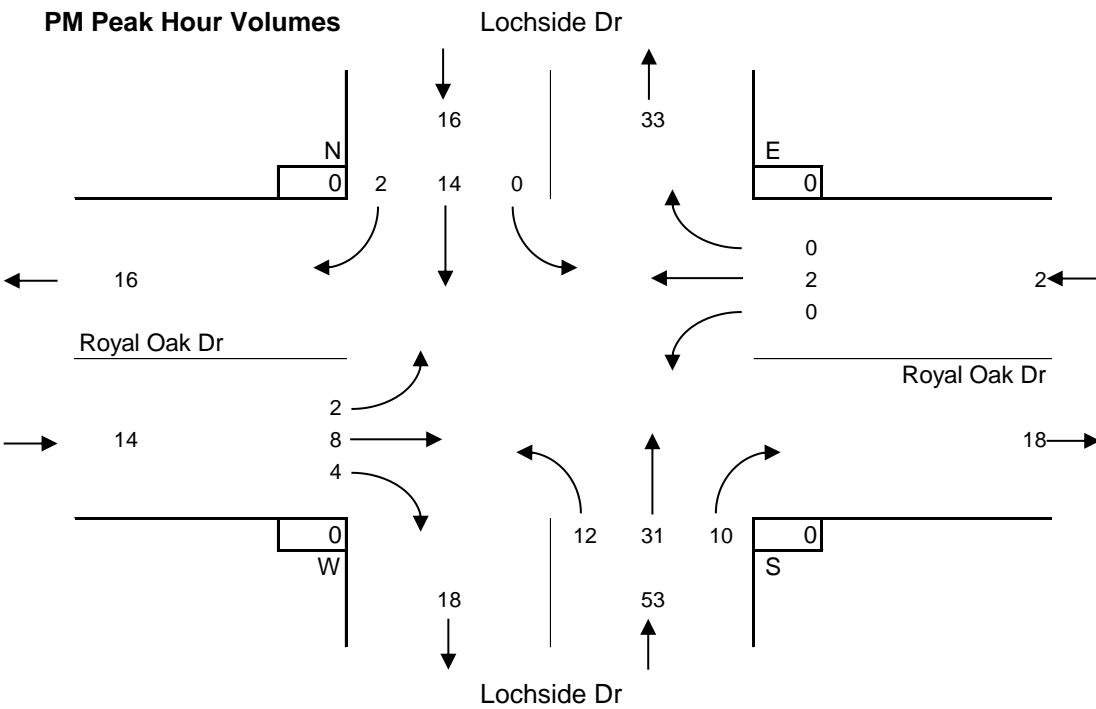

Entire Survey Period

5 Hours

	Lochside Dr				Lochside Dr				Royal Oak Dr				Royal Oak Dr				Total Volume				
	NORTH Approach				SOUTH Approach				WEST Approach				EAST Approach					N	S	W	E
	Left	Thru	Right	Total	Left	Thru	Right	Total	Left	Thru	Right	Total	Left	Thru	Right	Total					
Total	9	70	8	87	19	86	15	120	5	18	20	43	9	10	12	31	281	0	0	0	0
Avg Hr	2	14	2	17	4	17	3	24	1	4	4	9	2	2	2	6	56	0	0	0	0

AM Peak Period

2 Hours

	Lochside Dr				Lochside Dr				Royal Oak Dr				Royal Oak Dr				Total Volume				
	NORTH Approach				SOUTH Approach				WEST Approach				EAST Approach					N	S	W	E
	Left	Thru	Right	Total	Left	Thru	Right	Total	Left	Thru	Right	Total	Left	Thru	Right	Total					
Totals	2	44	1	47	2	23	1	26	2	9	14	25	8	3	6	17	115	0	0	0	0
Avg Hr	1	22	1	24	1	12	1	13	1	5	7	13	4	2	3	9	58	0	0	0	0

MD Peak Period

Hours

	Lochside Dr				Lochside Dr				Royal Oak Dr				Royal Oak Dr				Total Volume				
	NORTH Approach				SOUTH Approach				WEST Approach				EAST Approach					N	S	W	E
	Left	Thru	Right	Total	Left	Thru	Right	Total	Left	Thru	Right	Total	Left	Thru	Right	Total					
Total																					
Avg Hr																					

PM Peak Period

3 Hours

	Lochside Dr				Lochside Dr				Royal Oak Dr				Royal Oak Dr				Total Volume				
	NORTH Approach				SOUTH Approach				WEST Approach				EAST Approach					N	S	W	E
	Left	Thru	Right	Total	Left	Thru	Right	Total	Left	Thru	Right	Total	Left	Thru	Right	Total					
Totals	7	26	7	40	17	63	14	94	3	9	6	18	1	7	6	14	166	0	0	0	0
Avg Hr	2	9	2	13	6	21	5	31	1	3	2	6	0	2	2	5	55	0	0	0	0

